



# KORG

*EC Concert Pianos*





KORG - HOME ENTERTAINMENT PIANOS

# EC Concert Pianos

*Introducing the EC range of  
concert pianos from KORG  
designed for the home*





# EC

T H H E E X P E R I E N C E  
B E H I N D T H E N A M E

*Founded in 1962, Korg has always had a reputation for delivering the best possible musical sound quality from the technology available at the time. The EC range of concert pianos continues this tradition. The story begins in the early 60's, with the meeting of two men who shared a common passion for music; Tadashi Osanai, a renowned Japanese musician and qualified electronics engineer, and Tsutomu Katoh, an entertainment entrepreneur.*

Disappointed with the sound quality of the electronic musical instruments of the time, Osanai persuade Katoh to finance his endeavours to design better sounding units. Within a few months he had presented Katoh with a product which represented a major technological breakthrough and the fledgling company was in business, quickly establishing a reputation for instruments which satisfied the needs and aspirations of working musicians.

In 1979, integrated circuits revolutionized the art of synthesiser design and Korg used them to develop several products including legendary M1 Music Workstation, perhaps the most played keyboard in history. Thousands are still in use by professional musicians around the world today.

Korg utilized emerging technology's to develop another long term success story, the SG-1D Sampling Grand Piano. Previous technologies had not delivered sufficient fidelity and accuracy for Korg to put their name to a piano sound, but with the SG-1D Korg quickly became the market leader in stage pianos and today almost a decade later, the SG-1D is still the piano sound in many a professional keyboard player stage rig and a staple product of the stage piano hire market. Domestic pianos followed using the same technology and quickly earned Korg the same reputation in the home market. It was a Korg piano which came out top in Keyboard magazine's 1989 round up of all the digital pianos available at that time.

Not satisfied with these accolades from the most discerning ears in the world, Korg have continued to refine the use of PCM technology to the maximum, culminating in their most recent stage piano, the SG Pro X, and is fast taking over as the instrument of choice in some of the most prestigious live performance situations – from the London Philharmonia through Richard Clayderman to the Rolling Stones' and Eric Clapton's live keyboard rigs.

This is the legacy of innovation and attention to the professional musician's needs which Korg now brings to the design of instruments for the home user – the EC Concert piano series. As a result, Korg concert pianos capture the essence of traditional instruments, from richness of tone to sensitivity of touch. But they also offer the very best of Korg's expertise in electronic design at an accessible price point. Almost four decades have passed and the technology has changed beyond recognition, but Korg's philosophy remains the same – a commitment to the best possible sound quality at an affordable price.



# EC-500

K O R G C O N C E R T P I A N O S



Connect to a PC host

*Classically-trained pianists will feel right at home on the EC-500 due to completely authentic sound (sampled using the latest technology) and weighted feel, whilst those developing their musical skills will develop the best technique.*

The ability to connect directly to a PC or Mac computer is just one of the features ideal for students and music teachers, while the on-board recording capability of the EC-500/300 really is in a class of its own. Whatever your ability, a 16-track sequencer, with simple 'recorder' type controls – including full drum kit and bass sounds – enables you to play, store and modify a wide variety of music and save up to 10 songs on the piano. From classical compositions to jazz trios played on a range of instruments which include a majestic pipe organ and an electronic piano – listening to the rich sounds of the five superb demo songs created on the EC-500 will make you appreciate just what can be achieved.



Built-in sounds

And of course all songs or performances can be downloaded for additional storage on a computer, a particularly useful feature for teachers, students and beginners, as well as professional performing musicians.



EC-500 16-track sequencer





EC-500 Concert Piano

Naturally you will want to add your own effects to the music you create and record. Increase or diminish reverberation at the touch of a button and you can sound as if you are playing in a concert hall or small room. Transpose the pitch to match other instruments. Or select a different temperament – perhaps to play classical music exactly as it was originally composed. The EC range has the specification to be able to respond to your every creative wish.

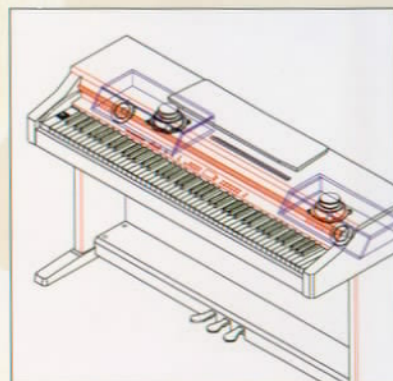

EC-500 speaker system



# EC-300

K O R G C O N C E R T P I A N O S

*The EC-300 features the same world-class sound quality, and though smaller in size and less powerful, the EC-300 should not be seen as an 'economy' model, but a fully featured variant of the EC-500, for use in situations where the EC-500 would be overpowering.*



Whether you choose to perform a classical masterpiece, a well-known rock song or your own composition created using the state-of-the-art 16-track sequencer, it will be heard to best advantage on the EC-500's superior four-way speaker sound system with a powerful 2 x 40 watt amplifier or on the EC-300's advanced two-speaker system with a 2 x 20 watt amplifier.

Attention to detail makes the EC range a pleasure to use. For example, to help you play accurately in tempo, an on-board metronome with a true 'click' (created using an actual sample) can also be easily adjusted to emphasise any 'down' beat.

These instruments not only sound like traditional pianos – they feel like traditional pianos, thanks to the precise weighting of the keys and the fidelity of digital sound technology. And with features including real rosewood, a compact design, and an attractive lustre finish, they will also enhance the appearance of any room or venue.



EC-300 Concert Piano



Music stand

# EC-100

K O R G C O N C E R T P I A N O S



*Precise key weighting*



*EC-100 Concert Piano*

*Solid construction, stylish finish and a feature list honed to the essentials makes the EC-100 the most affordable of concert piano range.*

Although we have concentrated on sound quality in the EC-100, we were still able to include the following features: 14 watt per channel stereo amplifier, 6 sound programs including a stereo piano, on-board effects and sequencing, metronome, 2 line inputs and 2 headphone outputs.

The EC-100 is available in two versions with standard weighted action keyboard (EC-100) or with a weighted keyboard with hammer action (EC-100H), ideal for proper piano practice on a digital instrument.

The EC-100 represents a perfect introduction to the quality of Korg Digital Pianos.







# Korg Concert EC-500/EC-300/EC-100

## Specifications

	EC-100/EC-100H	EC-300	EC-500
Keyboard	EC-100 88 note (weighted keyboard – velocity sensitive) EC-100H 88 note (weighted and hammer action keyboard velocity-sensitive)	88 note (weighted and hammer action keyboard – velocity sensitive)	
Touch Control	Light, Standard, Heavy		
Tone generator	AI <sup>2</sup> Synthesis System		
Polyphony	Max. 32 notes		
Sound programs	Piano (Stereo Sample), Electric Piano, Harpsichord, Vibraphone, Organ, Strings	Piano 1 (Stereo Sample), Piano 2, Electric Piano, Harpsichord, Vibraphone, Organ, Strings, 1 Drum Kit, 8 Bass programs	
Effects	Reverb Chorus	Surround (Room/Hall/Presets), Effect (Chorus/Tremolo)	
Recorder	1 tracks, 4,000 events Play, Record	16 tracks, 10 songs (maximum 31,000 events) Reset, Start/Stop, Record, REW, FF, Repeat, Song Select, Part Select	
Metronome	Tempo, Beat, Volume		
Display	–	8-Segment LED x 3	
Pedal controls	Soft, Damper or Sostenuto	Sostenuto, Soft, Damper	
Connectors	Output (L/MONO, R), Input (L/MONO, R), Headphones x 2, MIDI (IN, OUT)	Output (L/MONO, R), Input (L/MONO, R), Headphones x 2, MIDI (IN, OUT), PC I/F (TO HOST)	
Main amplifier	2 x 14W	2 x 22W	2 x 40W
Speakers	2 (2 x 13cm)	2 (2 x 13cm)	4 (2 x 13cm + 2 x 6.5cm)
Power supply	AC local voltage		
Power consumption	55W	85W	110W
Dimensions	1380 (W) 815 (H) 480 (D)	1400 (W) 847 (H) 498 (D)	1410 (W) 867 (H) 508 (D)
Colour and grain	Dark wine-red rosewood		
Options	–	AG-001/AG-001A, AG-002, AG-004	
Weight	48kg (51.5kg EC-100H)	54kg	69.5kg



EC-500 Concert Piano



EC-300 Concert Piano



EC-100 Concert Piano

 AI<sup>2</sup> Synthesis System

# KORG

KORG INC. 15-12, Shimotakaido 1-Chome, Suginami-Ku, Tokyo, Japan.  
KORG USA INC. 316 South Service Road, Melville, NY 11747, USA.  
KORG (UK) 9 Newmarket Court, Kingston, Milton Keynes MK10 0AU, UK.  
KORG Italy s.p.a. – Via Cagliata 85, 60027 Osimo (AN), Italy.

NOTICE: Korg products are manufactured under strict specifications and voltages required by each country. These products are warranted by the Korg distributor in the country where they are purchased. Any Korg product not sold with a warranty card or carrying a serial number disqualifies that product sold from the manufacturer's distributor's warranty and liability. This requirement is for your own protection and safety.

- Specifications and features are subject to change without notice.
- Colour reproduction in printed materials may differ from the actual product appearance.
- Some products may not be available in every country. Please consult KORG dealer nearest you for availability.